



PRODUCT: Structural Insulated Panels (SIPs)
DIVISION: Wood and Plastics (06)
SECTION: Structural Panels (06 12 16)

Report Holder
Structural Insulated Panel Association (SIPA)
PO Box 1699
Gig Harbor, WA 98335

Manufacturing Locations

PorterCorp (NTA Plant #538)
4240 North 136th Avenue
Holland, MI 49424

1. SUBJECT

PorterCorp Structural Insulated Panels. Wall and Roof Panels 8 ft. to 20 ft. long, 4-5/8 in. to 12-1/4 in. thick.

2. SCOPE

2.1. NTA, Inc. has evaluated the above product(s) for compliance with the applicable sections of the following codes:

- 2.1.1. 2006, 2009 International Building Code (IBC)
- 2.1.2. 2006, 2009 International Residential Code (IRC)

2.2. NTA, Inc. has evaluated the above product(s) in accordance with:

- 2.2.1. NTA IM 014 Structural Insulated Panel Evaluation
- 2.2.2. NTA IM 036 Quality System Requirements

2.3. NTA, Inc. has evaluated the following properties of the above product(s):

- 2.3.1. Structural performance under axial, transverse and racking loads.

To obtain the most current NTA Listing Report visit www.ntainc.com/product-certification/.

3. USES

3.1. **General.** *PorterCorp Structural Insulated Panels* are used as structural insulated roof and wall panels capable of resisting transverse, axial and in-plane shear loads.

3.2. **Construction Types.** *PorterCorp Structural Insulated Panels* shall be considered combustible building elements when determining the Type of Construction in accordance with 2009 IBC Chapter 6. (IM 014 NACU1)

3.3. **Fire Resistive Assemblies.** *PorterCorp Structural Insulated Panels* shall not be used as part of a fire-rated assembly unless suitable evidence and details are submitted and approved by the authority having jurisdiction. (IM 014 ACU14)

4. DESCRIPTION

4.1. **General.** *PorterCorp Structural Insulated Panels* are factory-assembled, engineered-wood-faced, structural insulated panels (SIPs) with an expanded polystyrene (EPS) foam core. The panels are intended for use as load-bearing or non-load bearing wall and roof panels. Panels are available in 4-5/8 in. through 12-1/4 in. overall thicknesses. The panels are custom made to the specifications for each use and are assembled under factory-controlled conditions. The maximum panel size is 8 ft. wide and up to 20 ft. in length.

4.2. Materials

4.2.1. **Facing.** The facing consists of two single-ply oriented strand board (OSB) facings a minimum of 7/16 in. thick conforming to 2009 IRC Table 613.3.2 and DOC PS 2-04, Exposure 1, Rated Sheathing with a span index of 24/16. Panels may be manufactured with the facing strength axis oriented in either direction with respect to the direction of SIP bending provided the appropriate strength values are used.

4.2.2. **Core.** The core material is EPS Foam conforming to the Type I specification defined in ASTM C578. The foam core, up to 11-3/8 in. thickness, has a flame spread rating not exceeding 75 and a smoke-developed rating not exceeding 450 in compliance with 2009 IBC Section 2603.3 Exception 4.

4.2.3. **Adhesive.** Facing materials are adhered to the core material using a structural adhesive. The adhesive is applied during the lamination process in accordance with the in-plant quality system documentation.

This listing report is intended to indicate that NTA Inc. has evaluated product described and has found it to be eligible for labeling. Product not labeled as specified herein is not covered by this report. NTA Inc. makes no warranty, either expressed or implied, regarding the product covered by this report.

NTA, INC. • 305 NORTH OAKLAND AVENUE • P.O. BOX 490 • NAPPANEE, INDIANA 46550
WEB: WWW.NTAINC.COM

PHONE: 574-773-7975
FAX: 574-773-2260

PSC121907-22 Listing Report 2012-04-05

Issue/Revision Date: 04/05/2012
This report is subject to annual renewal.

Page 1 of 10

4.2.4. Material Sources. The facing, core and adhesive used in the construction of *PorterCorp Structural Insulated Panels* shall be composed only of materials from approved sources as identified in the in-plant quality system documentation. A list of material suppliers is provided in Table 9.

4.2.5. Splines. *PorterCorp Structural Insulated Panels* are interconnected with surface splines or block splines (Figure 1). Connections using dimensional lumber splines or engineered structural splines are not specifically addressed in this report and must be designed in accordance with accepted engineering practice to meet applicable code requirements. ^(IM 014 ACU20)

4.2.5.1. Surface Splines. Surface splines (Figure 1) consist of 3 in. wide by 7/16 in. thick or thicker OSB. At each panel joint, one surface spline is inserted into each of two tight-fitting slots in the core. The slots in the core are located just inside the facing.

4.2.5.2. Block Splines. Block splines (Figure 1) are manufactured in the same manner as the SIP except with an overall thickness that is 1 in. less than the overall thickness of the panel to be joined.

5. DESIGN

5.1. Overall Structural System. The scope of this report is limited to the evaluation of the SIP component. Panel connections and other details related to incorporation of the panel into the overall structural system of a building are beyond the scope of this report. ^(IM 014 NACU3)

5.2. Design Approval. Where required by the authority having jurisdiction, structures using *PorterCorp Structural Insulated Panels* shall be designed by a registered design professional. Construction documents, including engineering calculations and drawings providing floor plans, window details, door details and connector details, shall be submitted to the code official when application is made for a permit. The individual preparing such documents shall possess the necessary qualifications as required by the applicable code and the professional registration laws of the state where the construction is undertaken. Approved construction documents shall be available at all times on the jobsite during installation. ^(IM 014 NACU4)

5.3. Design Loads. Design loads to be resisted by the SIPs shall be as required under the applicable building code. Loads on the panels shall not exceed the loads noted in this report.

5.4. Allowable Loads. Allowable axial, transverse, and racking loads may be calculated using the panel properties provided in Tables 1 and 2 or may be selected from Tables 3 through 7. Maximum and minimum panel heights, spans and thicknesses are limited as provided in Table 2 through 7. Unless otherwise noted, all properties and allowable loads apply to panels joined with surface or block splines. Allowable loads for reinforced panel capacities shall be designed by a registered professional. Calculations demonstrating that the loads applied are less than the allowable loads described in this report shall be submitted to the code official for approval. ^(IM 014 NACU5) For loading conditions not specifically addressed herein, structural members designed in accordance with accepted engineering practice shall be provided to meet applicable code requirements.

5.5. Concentrated Loads. Axial loads shall be applied to the SIP through continuous members such as structural insulated roof or floor panels or repetitive members such as joists, trusses or rafters spaced at regular intervals of 24 in. on center or less. Such members shall be fastened to a rim board or similar member to distribute the load to the SIP. For other loading conditions, reinforcement shall be provided. This reinforcement shall be designed in accordance with accepted engineering practice. ^(IM 014 ACU12)

5.6. Eccentric and Side Loads. Axial loads shall be applied concentrically to the top of the SIP. Loads shall not be applied eccentrically or through framing attached to one side of the panel (such as balloon framing) except where additional engineering documentation is provided. ^(IM 014 ACU13)

5.7. Openings. Openings in panels shall be reinforced with wood or steel designed in accordance with accepted engineering practice to resist all loads applied to the opening as required by the adopted code. Details for door and window openings shall be provided to clarify the manner of supporting axial, transverse and/or racking shear loads at openings. Such details shall be shown on approved design documents and subject to approval by the local authority having jurisdiction. ^(IM 014 ACU8)

This listing report is intended to indicate that NTA Inc. has evaluated product described and has found it to be eligible for labeling. Product not labeled as specified herein is not covered by this report. NTA Inc. makes no warranty, either expressed or implied, regarding the product covered by this report.

5.8. In-Plane Shear Design. Shear walls utilizing block or surface splines shall be sized to resist all code required wind and seismic loads without exceeding the allowable loads provided in Tables 6 and 7. Shear wall chords, hold-downs and connections to transfer shear forces between the wall and surrounding structure shall be designed in accordance with accepted engineering practice. Allowable strengths for shear walls with structural splines along each panel edge shall be designed in accordance with accepted engineering practice and subject to the limitations for wood sheathed shear walls.

5.8.1. Seismic Design Categories A, B and C. The use of the shear wall configurations in Table 6 is limited to structures in Seismic Design Categories A, B and C. Where SIPs are used to resist seismic forces the following factors shall be used for design: Response Modification Coefficient, $R = 2.0$; System Overstrength Factor, $\Omega_0 = 2.5$; Deflection Amplification Factor, $C_d = 2.0$.^(IM 014 ACU16) The maximum panel height-to-width ratio shall be 2:1.^(IM 014 ACU17)

5.8.2. Seismic Design Categories D, E, and F. The shear wall configurations in Table 7 are permitted in Seismic Design Categories D, E and F. Such walls shall be designed using the seismic design coefficients and limitations provided in ASCE 7-05 for light-framed walls sheathed with wood structural panels rated for shear resistance (SFRS A13). These SIPs shall use the following factors for design: Response Modification Coefficient, $R = 6.5$; System Overstrength Factor, $\Omega_0 = 3.0$; Deflection Amplification Factor, $C_d = 4.0$.^(IM 014 ACU16) The maximum panel height-to-width ratio shall be 1:1.^(IM 014 ACU17)

5.8.3. Adhesives and Sealants. Adhesives and sealants shall not be applied at wood-to-wood or spline-to-facing interfaces in shear walls in Seismic Design Categories D, E and F.^(IM 014 NACU10) Adhesives and sealants may be applied to wood-to-foam or facing-to-foam interfaces. Flexible SIP tape may be applied over panel joints.

5.9. Horizontal Diaphragms. Horizontal diaphragms shall be sized to resist all code required wind and seismic loads without exceeding the allowable loads provided in Table 8. Diaphragm chords and connections to transfer shear forces between the diaphragm and surrounding structure shall be designed in accordance with accepted engineering practice. The maximum diaphragm length-to-width ratio shall not exceed 3:1.^(IM 014 ACU18)

5.10. Combined Loads. Panels subjected to any combination of transverse, axial or in-plane shear loads shall be analyzed utilizing a straight line interaction in accordance with *NTA IM014 TIP 01 SIP Design Guide*.

6. INSTALLATION

6.1. General. *PorterCorp Structural Insulated Panels* shall be fabricated, identified and erected in accordance with this report, the approved construction documents and the applicable code. In the event of a conflict between the manufacturer's published installation instructions and this report, this report shall govern. Approved construction documents shall be available at all times on the jobsite during installation.^(IM 014 NACU7)

6.2. Splines. *PorterCorp Structural Insulated Panels* are interconnected at the panel edges through the use of a spline. The spline type may be of any configuration listed in Section 4.2.5 as required by the specific design. The spline shall be secured in place with not less than 0.131 in. x 2-1/2 in. nails, spaced 6 in. on center on both sides of the panel, or an approved equivalent fastener. All joints shall be sealed in accordance with the SIP manufacturer's installation instructions. Alternate spline connections may be required for panels subjected to in-plane racking forces. Such panels shall be interconnected exactly as required in Table 6 or 7 or as directed by the designer.

6.3. Plates. The top and bottom plates of the panels shall be dimensional or engineered lumber sized to match the core thickness of the panel. The plates shall be secured using not less than 0.131 in. x 2-1/2 in. nails, spaced 6 in. on center on both sides of the panel, or an approved equivalent fastener.

A second plate composed of 1-1/8 in. minimum thickness dimensional or engineered lumber with a specific gravity of 0.42 that is cut to the full thickness of the panel shall be secured to the first top plate using 0.131 in. x 3 in. nails or an approved equivalent fastener.

6.4. Cutting and Notching. No field cutting or routing of the panels shall be permitted except as shown on approved drawings.^(IM 014 NACU6)

6.5. Protection from Decay. SIPs that rest on exterior foundation walls shall not be located within 8 in. of exposed earth. SIPs supported by concrete or masonry that is in direct contact with earth shall be protected from the concrete or masonry by a moisture barrier.^(IM 014 ACU6)

This listing report is intended to indicate that NTA Inc. has evaluated product described and has found it to be eligible for labeling. Product not labeled as specified herein is not covered by this report. NTA Inc. makes no warranty, either expressed or implied, regarding the product covered by this report.

6.6. Protection from Termites. In areas subject to damage from termites, SIPs shall be protected from termites using an approved method. Panels shall not be installed below grade or in contact with earth. ^(IM 014 ACU7)

6.7. Heat-Producing Fixtures. Heat-producing fixtures shall not be installed in the panels unless protected by a method approved by the code official or documented in test reports. This limitation shall not be interpreted to prohibit heat-producing elements with suitable protection. ^(IM 014 NACU9)

6.8. Voids and Holes

6.8.1 Voids in Core. In lieu of openings designed in accordance with section 5.7, the following voids are permitted. Voids may be provided in the panel core during fabrication at predetermined locations only. Voids parallel to the panel span shall be limited to a single 1 in. maximum diameter hole. Such voids shall be spaced a minimum of 4 ft. on center measured perpendicular to the panel span. Two 1/2 in. diameter holes may be substituted for the single 1 in. hole provided they are maintained parallel and within 2 in. of each other. ^(IM 014 ACU11)

Voids perpendicular to the panel span shall be limited to a single 1 in. maximum diameter hole placed not closer than 16 in. from the support. Additional voids in the same direction shall be spaced not less than 28 in. on center.

6.8.2 Holes in Panels. Holes may be placed in panels during fabrication at predetermined locations only. Holes shall be limited to 4 in. x 4 in. square. The minimum distance between holes shall not be less than 4 ft. on center measured perpendicular to the panel span and 24 in. on center measured parallel to the panel span. Not more than three holes shall be permitted in a single line parallel to the panel span. The holes may intersect voids permitted elsewhere in this report. ^(IM 014 ACU15)

6.9. Panel Cladding

6.9.1 Roof Covering. The roof covering, underlayment and flashing shall comply with the applicable code(s). All roofing materials must be installed in accordance with the manufacturer's installation instructions. The use of roof coverings requiring the application of heat during installation shall be reviewed and approved by a registered design professional.

6.9.2 Exterior Wall Covering. Panels shall be covered on the exterior by a water-resistive barrier as required by the applicable code. The water-resistive barrier shall be attached with flashing in such a manner as to provide a continuous water-resistive barrier behind the exterior wall veneer. ^(IM 014 ACU9) The exterior facing of the SIP wall shall be covered with weather protection as required by the adopted building code or other approved materials. ^(IM 014 ACU10)

6.9.3 Interior Finish. The SIP foam plastic core shall be separated from the interior of the building by an approved thermal barrier of 1/2 in. gypsum wallboard or equivalent thermal barrier where required by 2009 IBC Section 2603.4.

7. CONDITIONS OF USE

PorterCorp Structural Insulated Panels as described in this report comply with the codes listed in Section 2.0, subject to the following conditions:

- 7.1.** Installation complies with this report and the approved construction documents.
- 7.2.** This report applies only to the panel thicknesses specifically listed herein. ^(IM 014 ACU3)
- 7.3.** In-use panel heights/spans shall not exceed the values listed herein. Extrapolation beyond the values listed herein is not permitted. ^(IM 014 ACU2)
- 7.4.** The panels are manufactured in the production facilities noted in this report. ^(IM 014 NACU8)

This listing report is intended to indicate that NTA Inc. has evaluated product described and has found it to be eligible for labeling. Product not labeled as specified herein is not covered by this report. NTA Inc. makes no warranty, either expressed or implied, regarding the product covered by this report.

8. EVIDENCE SUBMITTED

NTA, Inc. has examined the following evidence to evaluate this product:

- 8.1. Review of each manufacturing facility's quality system documentation for conformance to NTA IM 036.
- 8.2. Qualification test data in accordance with NTA IM 14 *Standard Evaluation Plan 01* (IM 014 SEP 01).
- 8.3. Periodic quality system audits of the production facilities.
- 8.4. Periodic testing in accordance with NTA IM 014.

Evaluation evidence and data are on file with NTA, Inc. NTA, Inc. is accredited by the International Accreditation Service (IAS) as follows:

ISO17020 Inspection Agency (AA-682)

ISO17025 Testing Laboratory (TL-259)

ISO Guide 65 Product Certification Agency (PCA-102)

The scope of accreditation related to testing, inspection or product certification pertain only to the test methods and/or standard referenced therein. Design parameters and the application of building code requirements, such as special inspection, have not been reviewed by IAS and are not covered in the accreditation. Product evaluations are performed under the direct supervision of Professional Engineers licensed in all jurisdictions within the United States as required by the building code and state engineering board rules.

9. FINDINGS

All products referenced herein are manufactured under an in-plant quality assurance program to insure that the production quality meets or exceeds the requirements of the codes noted herein and the criteria as established by NTA, Inc. Furthermore, panels must comply with the conditions of this report.

This report is subject to annual renewal.

10. IDENTIFICATION

Each eligible panel shall be permanently marked to provide the following information:

- a) The NTA, Inc. listing mark, shown below
- b) NTA's Listing No. SIPA120908-10
- c) In-plant quality assurance stamp
- d) Identifier for production facility
- e) Project or batch number.



This listing report is intended to indicate that NTA Inc. has evaluated product described and has found it to be eligible for labeling. Product not labeled as specified herein is not covered by this report. NTA Inc. makes no warranty, either expressed or implied, regarding the product covered by this report.

Table 1: Basic Properties^{1,2}

Property	Weak-Axis Bending	Strong-Axis Bending
Allowable Tensile Stress, F_t (psi)	245	495
Allowable Compressive Stress, F_c (psi)	340	580
Elastic Modulus (Bending), E_b (psi)	738900	658800
Shear Modulus, G (psi)	270	405
Allowable Core Shear Stress, F_v (psi)	4.5	5.0
Core Compressive Modulus, E_c (psi)	360	360
Reference Depth, h_o (in.)	4.625	4.625
Shear Depth Factor Exponent, m	0.84	0.86

¹ All properties are based on a minimum panel width of 24 in.

² Refer to NTA IM14 TIP 01 SIP Design Guide for details on engineered design using basic panel properties.

Table 2: Section Properties

Panel Thickness, h (in.)	Core Thickness, c (in.)	Dead Weight, w_d (psf)	Facing Area, A_f (in. ² /ft)	Shear Area, A_v (in. ² /ft)	Moment of Inertia, I (in. ⁴ /ft)	Section Modulus, S (in. ³ /ft)	Radius of Gyration, r (in.)	Centroid-to-Facing Dist., y_c (in.)
4.625	3.75	3.2	10.5	50.3	46.0	19.9	2.09	2.31
6.50	5.625	3.3	10.5	72.8	96.5	29.7	3.03	3.25
8.25	7.375	3.5	10.5	93.8	160.2	38.8	3.91	4.13
10.25	9.375	3.6	10.5	117.8	252.7	49.3	--	--
12.25	11.375	3.8	10.5	141.8	366.3	59.8	--	--



Figure 1: SIP Spline Types

This listing report is intended to indicate that NTA Inc. has evaluated product described and has found it to be eligible for labeling. Product not labeled as specified herein is not covered by this report. NTA Inc. makes no warranty, either expressed or implied, regarding the product covered by this report.

Table 3: Allowable Uniform Transverse Loads^{1,4}

Panel Length (ft)	4-5/8 inch Thick SIP			6-1/2 inch Thick SIP		
	Deflection Limit ²			Deflection Limit ²		
	L/180	L/240	L/360	L/180	L/240	L/360
8 WAB ³	50.8	40.9	27.3	73.8	64.7	43.1
8	68.8	51.6	34.4	80.6	80.6	56.6
10	45.1	33.8	22.5	62.0	57.9	38.6
12	30.8	23.1	15.4	50.4	40.9	27.3
14	21.7	16.3	--	39.6	29.7	19.8
16	--	--	--	29.4	22.1	14.7
18	--	--	--	22.4	16.8	--

See Table 4 for notes.

Table 4: Allowable Uniform Transverse Loads (continued)^{1,4}

Panel Length (ft)	8-1/4 inch Thick SIP			10-1/4 inch Thick SIP			12-1/4 inch Thick SIP		
	Deflection Limit ²			Deflection Limit ²			Deflection Limit ²		
	L/180	L/240	L/360	L/180	L/240	L/360	L/180	L/240	L/360
8 WAB ³	81.4	81.4	58.3	89.9	89.9	75.9	98.6	98.6	93.6
8	88.5	88.5	78.4	97.3	97.3	97.3	106.4	106.4	106.4
10	67.4	67.4	54.8	73.1	73.1	73.1	78.8	78.8	78.8
12	54.4	54.4	39.6	58.6	58.6	54.6	62.5	62.5	62.5
14	45.6	43.9	29.3	48.8	48.8	41.1	51.9	51.9	51.9
16	39.3	33.2	22.1	41.9	41.9	31.5	44.3	44.3	41.7
18	34.1	25.6	17.1	36.7	36.7	24.6	38.7	38.7	32.9
20	26.7	20.0	13.4	32.6	29.2	19.5	34.3	34.3	26.3

¹ Table values assume a simply supported panel with 1.5 in. of continuous bearing on facing at supports ($C_v = 1.0$) with solid wood plates at bearing locations. Values do not include the dead weight of the panel. For wall panel capacities utilizing a zero bearing configuration, shown in Figure 2, multiply the allowable uniform load shown by $C_v = 0.4$.

² Deflection limit shall be selected by building designer based on the serviceability requirements of the structure and the requirements of adopted building code. Values are based on loads of short duration only and do not consider the effects of creep.

³ Tabulated values are based on the strong-axis of the facing material oriented parallel to the direction of panel bending. WAB indicates weak-axis bending of the facing material; the strong-axis of the facing material is oriented perpendicular to the direction of panel bending.

⁴ Permanent loads, such as dead load, shall not exceed 0.50 times the tabulated load.

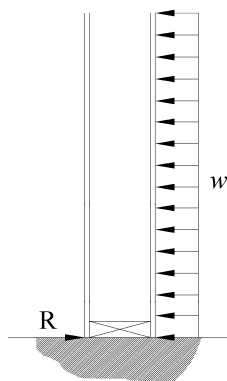

Figure 2: Zero Bearing Support

This listing report is intended to indicate that NTA Inc. has evaluated product described and has found it to be eligible for labeling. Product not labeled as specified herein is not covered by this report. NTA Inc. makes no warranty, either expressed or implied, regarding the product covered by this report.

Table 5: Allowable Axial Loads (plf)^{1,2,3,4}

Lateral Brace Spacing (ft)	Panel Thickness		
	4-5/8 inch	6-1/2 inch	8-1/4 inch
8 WAB⁵	2320	2470	2530
8	3630	4070	4240
10	3260	3890	4130
12	2810	3660	4000
14	--	3390	3830
16	--	3090	3640
18	--	2790	3430
20	--	--	3190

- ¹ Permanent loads, such as dead load, shall not exceed 0.50 times the tabulated load.
- ² All values are for normal duration and may not be increased for other durations.
- ³ Axial loads shall be applied concentrically to the top of the panel through repetitive members spaced not more than 24 in. on center. Such members shall be fastened to a rim board or similar member to distribute along the top of the SIP.
- ⁴ The ends of both facings must bear on the supporting foundation or structure to achieve the tabulated axial loads.
- ⁵ Tabulated values are based on the strong-axis of the facing material oriented parallel to the direction of panel bending. WAB indicates weak-axis bending of the facing material; the strong-axis of the facing material is oriented perpendicular to the direction of panel bending.

Table 6: Allowable In-Plane Shear Strength (Pounds per Foot) for SIP Shear Walls (Wind and Seismic Loads in Seismic Design Categories A, B and C)^{1,3}

Spline Type ⁴	Nominal SIP Thickness (in.)	Minimum Facing Connections ^{3,5}			Shear Strength (plf)
		Chord ³	Plate ³	Spline ⁴	
Block or Surface Spline	4.625	0.131"x 2-1/2" nails, 6" oc	0.131"x 2-1/2" nails, 6" oc	0.131"x 2-1/2" nails, 6" oc	380
	6.625	0.131"x 2-1/2" nails, 6" oc	0.131"x 2-1/2" nails, 6" oc	0.131"x 2-1/2" nails, 6" oc	380
	8.375	0.131"x 2-1/2" nails, 6" oc	0.131"x 2-1/2" nails, 6" oc	0.131"x 2-1/2" nails, 6" oc	400

See Table 7 for notes.

Table 7: Allowable In-Plane Shear Strength (Pounds per Foot) for SIP Shear Walls (Wind and Seismic Loads in Seismic Design Categories D, E and F)^{2,3}

Spline Type ⁴	Nominal SIP Thickness (in.)	Minimum Facing Connections ^{3,5}			Shear Strength (plf)
		Chord ³	Plate ³	Spline ⁴	
Block or Surface Spline	6.5	0.131"x 2-1/2" nails, 3" oc (3/8" edge distance)	0.131"x 2-1/2" nails, 3" oc (3/8" edge distance)	0.131"x 2-1/2" nails, 3" oc (23/32" thick, 3" wide spline)	900

- ¹ Maximum shear wall dimensions ratio shall not exceed 2:1 (height: width) for resisting wind or seismic loads.
- ² Maximum shear wall dimension ratio shall not exceed 1:1 (height: width) for resisting wind or seismic loads.
- ³ Chords, hold downs and connections to other structural elements must be designed by a registered design professional in accordance with accepted engineering practice.
- ⁴ Spline type at interior panel-to-panel joints only. Solid chord members are required at each end of each shear wall segment.
- ⁵ Required connections must be made on each side of the panel. Dimensional or engineered lumber shall have an equivalent specific gravity of 0.42 or greater.

This listing report is intended to indicate that NTA Inc. has evaluated product described and has found it to be eligible for labeling. Product not labeled as specified herein is not covered by this report. NTA Inc. makes no warranty, either expressed or implied, regarding the product covered by this report.

Table 8: Allowable In-Plane Shear Strength (Pounds per Foot) for Horizontal Diaphragms Subjected to Wind or Seismic Loading

Nominal SIP Thickness (in.)	Minimum Connections		Shear Strength (plf)	Max. Aspect Ratio	
	Block Spline ¹ (Figure 3a)	Boundary ² (Figure 3b)			
		Support			Spline
8.25	0.131" x 2-1/2" nails, 6" oc 7/16" x 3" x 7-3/8" OSB Surface Spline	10" Length, 0.190" shank diameter, 0.255" thread o.d., 2.750" thread length 0.625" head diameter SIP Screw 6" oc	0.131" x 2-1/2" nails, 6" oc	265	3:1
	0.131" x 2-1/2" nails, 4" oc 7/16" x 3" x 7-3/8" OSB Surface Spline	10" Length, 0.190" shank diameter, 0.255" thread o.d., 2.750" thread length 0.625" head diameter SIP Screw 4" oc	0.131" x 2-1/2" nails, 4" oc	330	3:1
	0.131" x 2-1/2" nails, 2" oc staggered 3/8" (Figure 3c) 7/16" x 3" x 7-3/8" OSB Surface Spline	10" Length, 0.190" shank diameter, 0.255" thread o.d., 2.750" thread length 0.625" head diameter SIP Screw 3" oc	0.131" x 2-1/2" nails, 2" oc staggered 3/8" (Figure 3c)	575	3:1

¹ Top spline or block spline only at interior panel-to-panel joints. Specified fasteners are required on both sides of panel joint through the top surface only, as shown in Figure 3a.

² Boundary spline shall be solid lumber 1.5 in. wide minimum and have a specific gravity of 0.42 or greater. Specified fasteners are required through both facings as shown in Figure 3b.

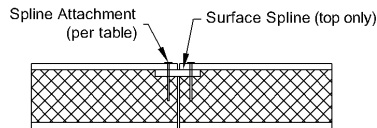

Figure 3a: Surface Spline

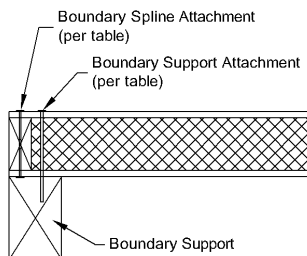

Figure 3b: Boundary

0.131" x 2 1/2" Nails, 2" O.C. (Staggered 3/8"),
Fasteners Applied to Both Sides at SPF Members and Only One Side (the Side Opposite of Load Application) at All Block Splines

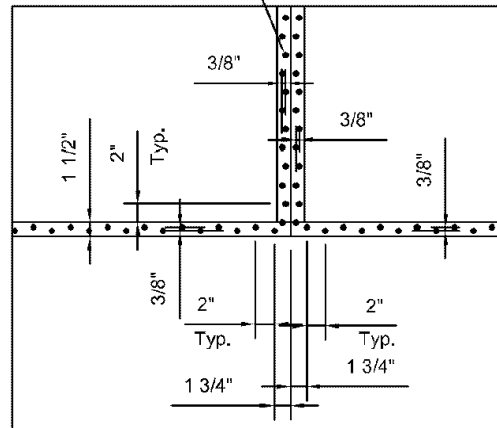

Figure 3c: Boundary Spline

Figure 3: Diaphragm Connection Types

This listing report is intended to indicate that NTA Inc. has evaluated product described and has found it to be eligible for labeling. Product not labeled as specified herein is not covered by this report. NTA Inc. makes no warranty, either expressed or implied, regarding the product covered by this report.

Table 9: Component Material Sources

Facing	Core	Adhesive
Ainsworth Group of Companies Suite 3194 Bentall 4 1055 Dunsmuir Street Vancouver BC, Canada V7X 1L3	ACH Corporation Plant U-37 - Fond du Lac, WI	Ashland Specialty Chemical Company 5200 Blazer Parkway Dublin, OH 43017
Georgia-Pacific 9918 Buford Bridge Road Fairfax, SC 29827	Atlas EPS, A Division of Atlas Roofing Corporation 8240 Byron Center Road SW Byron Center, MI 49315	Foam Supplies, Inc. 4387 N. Rider Trail Earth City, MO 63045
Huber Engineered Woods 1000 Chaney Lane Crystal Hill, VA 24539	Iowa EPS Products, Inc. 5554 N.E. 16 th Street Des Moines, IA 50313	Rohm and Haas Company 5005 Barnard Mill Road Ringwood, IL 60072
Louisiana-Pacific Corporation Sagola, MI Sales and Marketing by: Affiliated Resources, Inc. River Forum 1 4380 SW Macadam Avenue, Suite 200 Portland, OR 97239	Northwest Foam Products, Inc. 2390 Rostron Circle Twin Falls, ID 83301	
Tolko Industries, Ltd. 3203 30 th Avenue Vernon BC, Canada V1T 6M1	OPCO, Inc. P.O. Box 101 Latrobe, PA 15650	
	Plymouth Foam 1 Southern Gateway Drive Gnadenhutten, OH 44629	
	Polar Industries, Inc. 32 Gramar Avenue Prospect, CT 06712	
	Powerfoam Insulation 550 Murray Street/Highway 287 Midlothian, TX 76065	

This listing report is intended to indicate that NTA Inc. has evaluated product described and has found it to be eligible for labeling. Product not labeled as specified herein is not covered by this report. NTA Inc. makes no warranty, either expressed or implied, regarding the product covered by this report.

NTA, INC. • 305 NORTH OAKLAND AVENUE • P.O. BOX 490 • NAPPANEE, INDIANA 46550
 WEB: WWW.NTAINC.COM

PHONE: 574-773-7975
 FAX: 574-773-2260

PSC121907-22 Listing Report 2012-04-05

Issue/Revision Date: 04/05/2012
 This report is subject to annual renewal.
 Page 10 of 10